

Solar Electric Battery Car Using Microcontroller

¹M. SREENIVASA REDDY, ²S.V.S PRASAD, ³CH. SIVA NAGA SAI

(Associate Professor), Department of Electrical and Electronics Engineering, MLR Institute of Technology, Dundigal, Hyderabad

Abstract: The aim of our project is to utilize the maximum solar energy through solar panel and run a car. It is generally recognized that there is a need for new methods of affordable, non-polluting, personal transportation. A literature review shows that cars are very efficient, well understood machines, but that electric versions have had little commercial success over the past century. By applying modern power semiconductor technology, a standard separately-excited DC motor is now to efficiently propel a car. The practicality of such a vehicle was demonstrated by entering an early version. Compared to the other electric vehicles in the event, this electric car consumed a similar amount of power per mile per unit weight, but used the least power per mile, due to its small size. A final prototype demonstrates the full implementation of both mechanical and electrical components. To better analyze the motor, a non-linear model is used. It is shown that maximum efficiency is achieved by maintaining a fixed ratio between the armature and field currents.

Keywords: Microcontroller, well understood machines, applying modern power semiconductor technology.

1. INTRODUCTION

Electric cars are something that shows up in the news all the time. A solar car or vehicle is an electric vehicle powered by a type of renewable energy, by solar energy obtained from solar panels on the surface of the vehicle.

There are several reasons for the continuing interest in these vehicles: Electric cars create less pollution than gasoline-powered cars, so they are an environmentally friendly alternative to gasoline-powered vehicles (especially in cities). Any news story about ELECTRIC CAR cars usually talks about electric cars as well. Vehicles powered by cells are electric cars, and fuel cells are getting a lot of attention right now in the news. An electric car is a car powered by an electric motor rather than a gasoline.

From the outside, you would probably have no idea that a car is electric. In most cases, electric cars are created by converting a gasoline-powered car, and in that case it is impossible to tell. When you drive an electric car, often the only thing that clues you in to its true nature is the fact that it is nearly silent. Under the hood, there are a lot of differences between gasoline and electric cars. The gasoline engine is replaced by an electric motor. The electric motor gets its power from a controller. The controller gets its power from an array of rechargeable batteries. Project An electric car is definitely a wiring project. In order to get a feeling for how electric cars work in general, let's start by looking at a typical electric car to see how it comes together.

COMPONENT REQUIREMENT:

1. Dc series motor (1000watts)
2. Controller
3. Shaft
4. Batteries (12 volts) -4 No's
5. Brake pads

6. Steering
7. Dc sources
8. Ignition on/off
9. Gear rod

ELECTRIC VEHICLE TECHNICAL CONSIDERATIONS:

In general, Electric Vehicle outperform conventional vehicles in terms of fuel consumption and pollutant emissions. However, the degree of Electric Vehicle performance and cost savings achieved largely depend on its application (including the types of trips), the level of available technical service and maintenance, fuel price, and the availability of optimal fuel quality. A conventional vehicle has a mechanical drive car that includes the fuel tank, the combustion engine, the gear box, and the transmission to the wheels. A Electric Vehicle has two drive car - one mechanical and one electric. The electric drive train includes a battery, an electric motor, and power electronics for control.

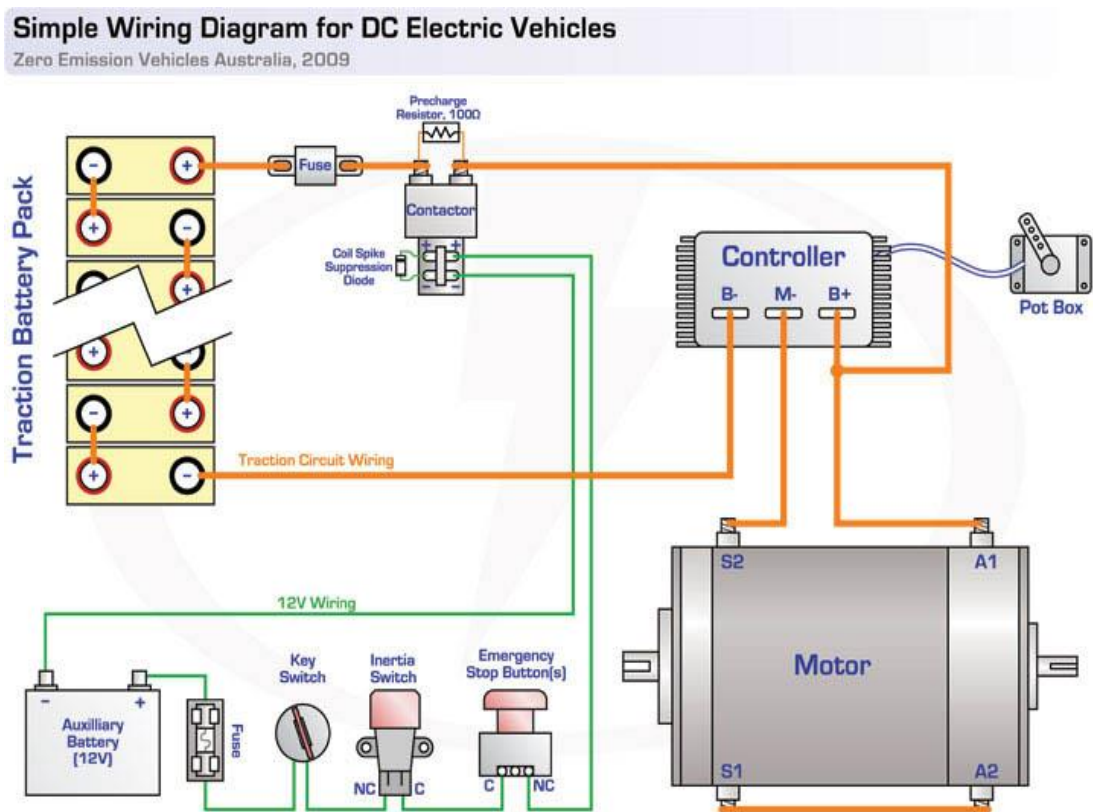

MUTHUKUMAR et al BLOCK DIAGRAM:

The range of this car is about 50 miles (80 km).The 0-to-60 mph time is about 15 seconds. It takes about 12 kilowatt-hours of electricity to charge the car after a 50-mile trip.

The batteries weigh about 1,100 pounds (500 kg).

The batteries last three to four years To compare the cost per mile of gasoline cars to this electric car, here's an example. Electricity in North Carolina is about 8 cents per kilowatt-hour right now (4 cents if you use time-of-use billing and recharge at night). That means that for a full recharge, it costs \$1 (or 50 cents with time-of-use billing). The cost per mile is therefore 2 cents per mile, or 1 cent with time-of-use. If gasoline costs \$1.20 per gallon and a car gets 30 miles to the gallon, then the cost per mile is 4 cents per mile for gasoline. Clearly, the "fuel" for electric vehicles costs a lot less per mile than it does for gasoline vehicles. And for many, the 50-mile range is not a limitation -- the average person living in a city or suburb seldom drives more than 30 or 40 miles per day. to be completely fair, however, we should also include the cost of battery replacement. Batteries are the weak link in electric cars at the moment. Battery replacement for this car runs about \$2,000. The batteries will last 20,000 miles or so, for about 10 cents per mile. You can see why there is so much excitement around fuel cells right now -- fuel cells solve the battery problem (more details on fuel cells later in the article).

SPECIFICATIONS:

DC MOTOR:

A **DC motor** is any of a class of electrical machines that converts direct current electrical power into mechanical power. The most common types rely on the forces produced by magnetic fields. Nearly all types of DC motors have some internal mechanism, either electromechanical or electronic, to periodically change the direction of current flow in part of the motor. Most types produce rotary motion; a linear motor directly produces force and motion in a straight line. To understand the DC motor in details let's consider the diagram below,



The direct current motor is represented by the circle in the center, on which is mounted the brushes, where we connect the external terminals, from where supply voltage is given. On the mechanical terminal we have a shaft coming out of the Motor, and connected to the armature, and the armature-shaft is coupled to the mechanical load. On the supply terminals we represent the armature resistance R_a in series. Now, let the input voltage E , is applied across the brushes. Electric current which flows through the rotor armature via brushes, in presence of the magnetic field, produces a torque T_g . Due to this torque T_g the dc motor armature rotates. As the armature conductors are carrying currents and the armature rotates inside the stator magnetic field, it also produces an emf E_b in the manner very similar to that of a generator. The generated Emf E_b is directed opposite to the supplied voltage and is known as the back Emf, as it counters the forward voltage.

The back emf like in case of a generator is represented by

$$E_b = \frac{P \cdot \phi \cdot Z \cdot N}{60 \cdot A} \text{-----(1)}$$

Where, P = no of poles; ϕ = flux per pole; Z = No. of conductors; A = No. of parallel paths and N is the speed of the DC Motor. So from the above equation we can see E_b is proportional to speed ' N '. That is whenever a direct current motor rotates, it results in the generation of back Emf. Now let's represent the rotor speed by ω in rad/sec. So E_b is proportional to ω .

So when the speed of the motor is reduced by the application of load, E_b decreases. Thus the voltage difference between supply voltage and back emf increases that means $E - E_b$ increases. Due to this increased voltage difference, armature current will increase and therefore torque and hence speed increases. Thus a DC Motor is capable of maintaining the same speed under variable load. Now armature current I_a is represented by

$$I_a = \frac{E - E_b}{R_a}$$

Now at starting, speed $\omega = 0$ so at starting $E_b = 0$.

$$\therefore I_a = \frac{E}{R_a} \text{-----(2)}$$

Now since the armature winding electrical resistance R_a is small, this motor has a very high starting current in the absence of back Emf. As a result we need to use a starter for starting a DC Motor. Now as the motor continues to rotate, the back Emf starts being generated and gradually the current decreases as the motor picks up speed.

Working Principles and Operation:

The underlying principles for the working of a BLDC motor are the same as for a brushed DC motor; i.e., internal shaft position feedback. In case of a brushed DC motor, feedback is implemented using a mechanical commutator and brushes. With a BLDC motor, it is achieved using multiple feedback sensors. The most commonly used sensors are hall sensors and optical encoders.

In a commutation system – one that is based on the position of the motor identified using feedback sensors – two of the three electrical windings are energized at a time as shown in figure 4.

In figure 4 (A), the GREEN winding labeled “001” is energized as the NORTH pole and the BLUE winding labeled as “010” is energized as the SOUTH pole. Because of this excitation, the South Pole of the rotor aligns with the GREEN winding and the North Pole aligns with the RED winding labeled “100”. In order to move the rotor, the “RED” and “BLUE” windings are energized in the direction shown in figure 4(B). This causes the RED winding to become the North Pole and the BLUE winding to become the South Pole. This shifting of the magnetic field in the stator produces torque because of the development of repulsion (Red winding – NORTH-NORTH alignment) and attraction forces (BLUE winding – NORTH-SOUTH alignment), which moves the rotor in the clockwise direction.

The BLDC Motor Drive:

All of today’s ELECTRIC CAR vehicles use a BLDC motor. Green car manufacturers often prefer BLDC motors over the alternatives because the peak point efficiency is higher and rotor cooling is simpler. The motors can also operate at “unity power factor,” meaning the drive can operate at its maximum efficiency levels.

Batteries and brakes one of the most important components of the BLDC motor drive system is the batteries. In addition, they allow the electrical receivers to function. Therefore, it’s important that the batteries in green cars be as efficient as possible.

Whenever a battery gets used, an irreversible change in the chemical structure occurs. As a result, a rechargeable battery is most efficient when maintained close to full charge. Thanks to the permanent magnets in the brushless DC motor and the ability for the external torque to work as a generator, a person operating a green car can pulse-charge the battery by applying the brakes. It’s important to note, however, that braking alone won’t fully charge an electric car’s battery. Motor response. Green car manufacturers and entities like NASA prefer BLDC motors because of their fast motor responses. The high-performance, small-diameter magnetic rotors reduce the inertia of the armature, allowing high acceleration rates, a reduction in rotational losses, and smoother servo characteristics. This optimal motor response also allows for more constant speeds, instant speed regulation and a quieter drive system

DC MOTOR CONTROLLER:



Controller internal diagram:

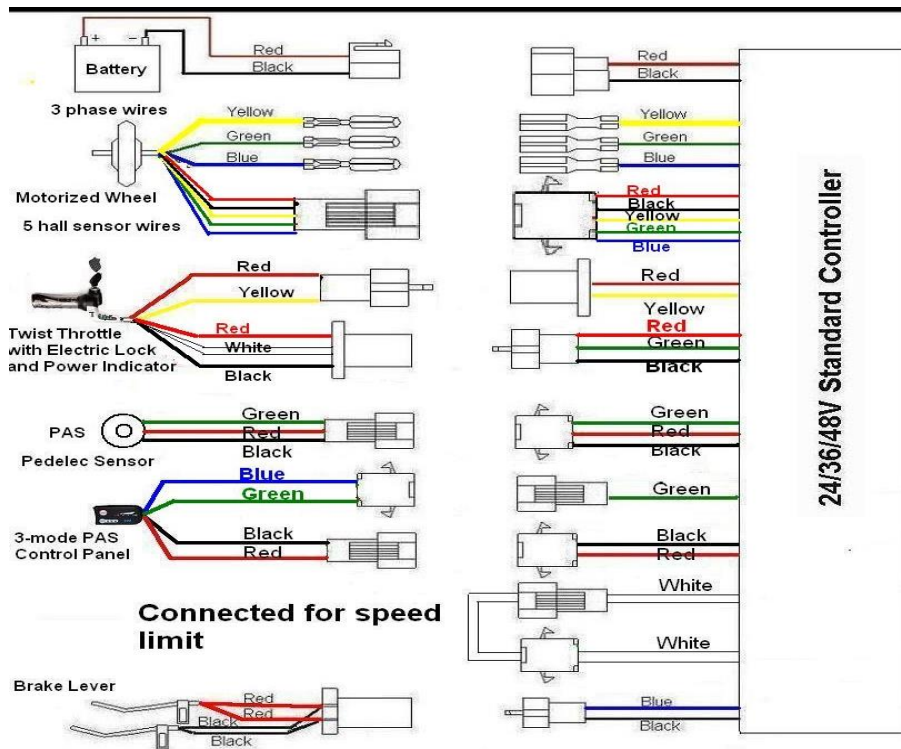

Axle:

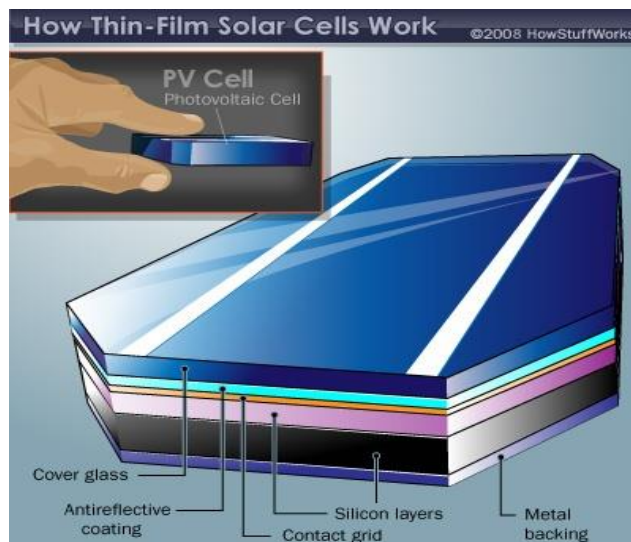

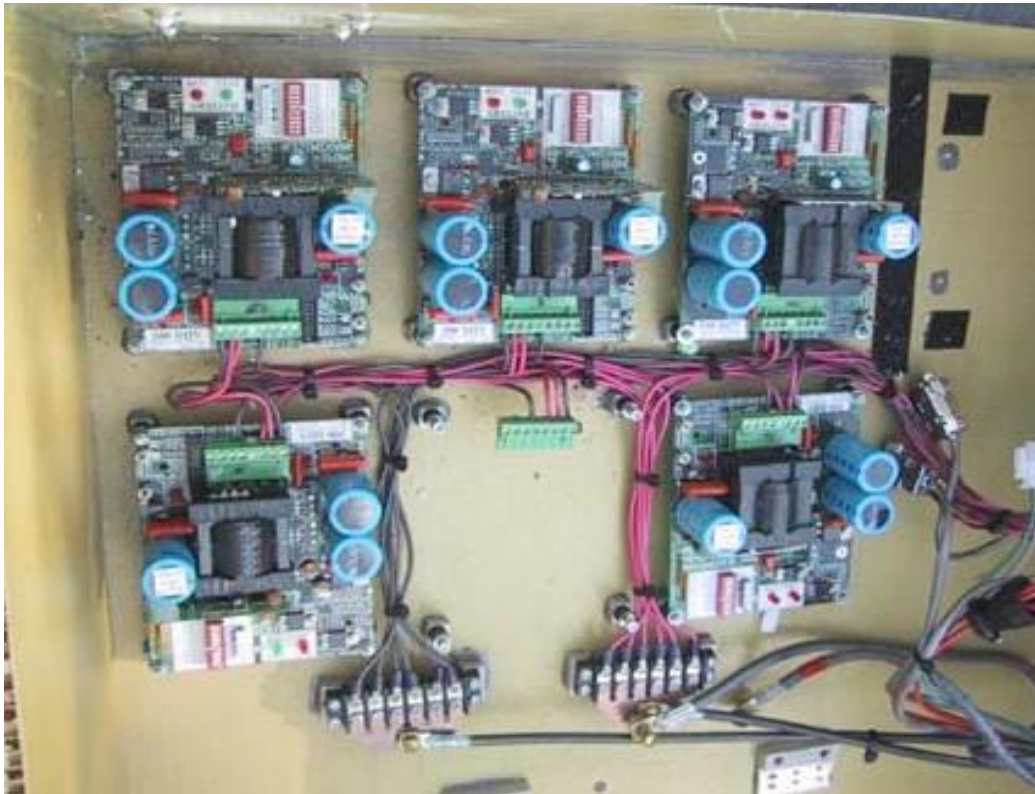

12V DC BATTERY:

Battery is the main power supply of a vehicle.

The batteries store energy from the power -- tracker and makes them available for the motor's.

A battery is a device that stores chemical energy and makes it available in an electrical form.

This energy is send to the motor and controller to make the car run.

An automotive battery is a type of rechargeable battery that supplies electric energy to an automobile.[1] An automotive SLI battery (starting, lighting, and ignition) powers the starter motor, the lights, and the ignition system of a vehicle's engine.

Automotive SLI batteries are usually lead-acid type, and are made of six galvanic in series to provide a 12-volt system. Each cell provides 2.1 volts for a total of 12.6 volts at full charge. Heavy vehicles, such as highway trucks or tractors, often equipped with diesel engines, may have two batteries in series for a 24-volt system or may have parallel strings of batteries.

How does a traditional automobile engine works?

For the last 100 years, Americans have primarily driven vehicles with internal combustion engines. An internal combustion (IC) engine burns fuel inside a combustion chamber when a mix of fuel and air is sprayed into it.

The mixture is compressed by a piston while a spark plug produces a spark that ignites the fuel. The resulting combustion, and the expanding gases, drives the piston back down.

The piston is connected to a crankshaft which, in turn, powers the axles and propels the vehicle.

See Figure for a cross-section diagram of part of an IC engine. Most modern vehicles use either gasoline or diesel as a fuel source because they are energy dense and inexpensive. Gases are a byproduct of the combustion.

The engine's exhaust valves remove them from the cylinder and send them on to the car's exhaust system. The engine's heat, another byproduct of the combustion process, is the source of a vehicle's heating system in the winter.

A critical element in a car's engine operation is the battery. When a driver turns the key in the ignition, the battery's stored energy is drawn down, powering the electric engine starter and thereby cranking the engine.

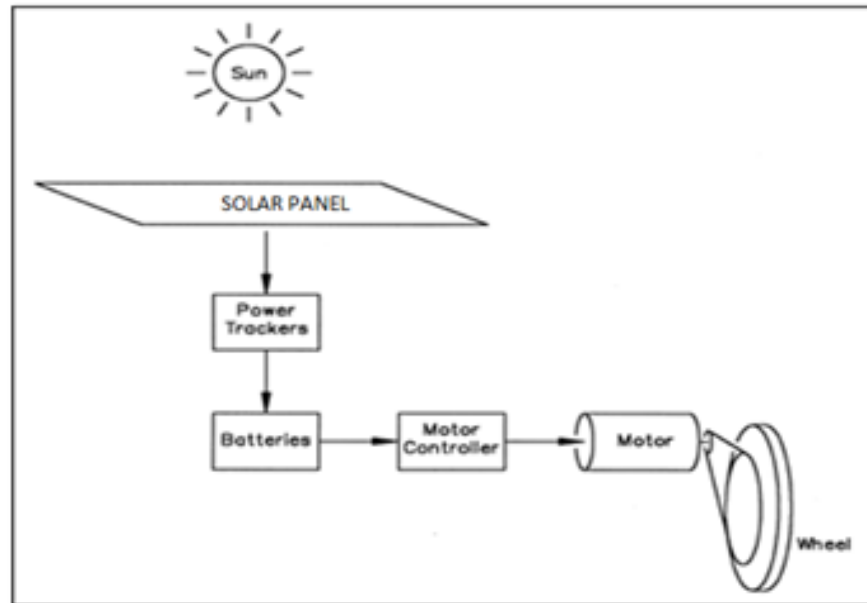

- A solar panel converts solar energy to electrical energy.
- Photons in sunlight provide the energy that moves electrons from one layer of a semi-conducting metallic wafer to another.
- The movement of the electrons creates a current.
- Solar panels are devices which convert solar energy directly into electricity.
- The most common solar panel function by the photovoltaic effect. Photo- means light and -voltaic means electrical current or electricity.

Operation of an Electric Vehicle:

- An electric vehicle operates differently from a vehicle with an IC engine. An all-electric vehicle is
- powered by electricity with a large, rechargeable battery, an electric motor, a controller that sends
- Electricity to the motor from the driver's accelerator pedal, and a charging system.

These parts of:

- an electric vehicle replace the IC engine, fuel tank, fuel line, and exhaust system in a traditional
- car.3 While the IC engine is central to the operation of a traditional vehicle, it is the rechargeable
- Battery that is central to the operation of an electric vehicle.
- All-electric vehicles recharge their batteries by plugging them into a household electrical outlet or
- A special charging station. As discussed later in this report, there are different kinds of electric
- 2 Not all engines have *internal* combustion. For example, steam engines burn fuel outside the engine.
- Some are all-electric and others are electrics, with small electric motors and small I engines (using both electricity and gasoline as a fuel). Some of the electrics can be plugged in for recharging, and others, such as the original Prius, are recharged from their gasoline engine another internal systems

CONCLUSION

Battery Manufacturing for Electric Vehicles:

16 metal plates set in an electrolyte solution of water (65%) and sulfuric acid (35%). The internal cell plates and separators are shown in Figure. The positive anode side of each plate is coated in lead oxide; the negative cathode side in lead. As electrons move from the anode, they generate up to 2 volts of electricity within each cell. The cells are arranged in a series so that the electricity passes from one cell to the other, making the charge additive. By the time the charge has passed through each of the six cells, 12 volts of electricity are discharged through the terminals on the top of the battery to start the car and run the other automotive components. This project can also be extended by using solar energy.

REFERENCES

- [1] Abedinpour, Bakkaloglu, Kiaei. "A Multistage Interleaved Synchronous Buck Converter with Integrated Output Filter in 0.18 μm SiGe Process," IEEE Transaction on Power Electronics, vol. 22, no. 6, pp. 2164–2175, Nov. 2007
- [2] Belloni, Bonizzoni, and Maloberti, "On the design of single-inductor double-output dc-dc buck, boost and buck-boost converters," 15th IEEE International Conference on in Electronics, Circuits and Systems, vol. 31pp. 626–629, 2008
- [3] A. Muetze, Y. C. Tan (2005), "Performance evaluation of electric bicycles", Industry Applications Conference, Vol. 4, pp - 2865 – 72
- [4] Brushless-DC Motor Drives for Electric Bicycles", IEEE International Conference on Electric Machines & Drives, Vol. 1, pp:140 – 47.
- [5] N. Somchaiwong, W. Ponglangka (2006), "Regenerative Power Control for Electric Bicycle", SICE-ICASE International Joint Conference, pp - 4362-4365.
- [6] Keoun, B.C "Designing an Electric Vehicle Conversion – South con/95", IEEE Conference Record Keoun, B.C. (1995), "Designing an Electric Vehicle Conversion", South con/95 Conference.
- [7] J. Breckling, Ed. (1989), "The Analysis of Directional Time Series: Applications to Wind Speed and Direction", ser. Lecture Notes in Statistics. Berlin, Germany: Springer, vol. 61.
- [8] H. Oman, W. C. Morchin, F. E. Jamerson (1995), "Electric-bicycle propulsion power, Microelectronics Communications Technology Producing Quality Products Mobile and Portable Power Emerging Technologies", pp - 555.
- [9] W.C. Morchin (1994), "Battery-powered electric bicycles", North con/94 Conference Record, pp - 269 –274.
- [10] Po-Lun Chang, Yu-Xin Gu, Mu-Der Jeng (2011), "Telematics gateway and power saving method for electric vehicles", IEEE International Conference on Systems, Man, and Cybernetics (SMC), pp - 780 – 785
- [11] Alminauskas. V., (1993), "Performance evaluation of lead acid batteries for use with solar panels", Photovoltaic Specialists Conference, pp - 1258 – 1263.
- [12] Wilkinson. H., (2005), "Avestor Lithium-Metal-Polymer Batteries Deployed throughout North America", Telecommunications Conference, pp - 217 – 221.
- [13] Xianlai Zeng, Jinhui Li, Yusen Ren, (2012), "Prediction of various discarded lithium batteries in China", IEEE International Symposium on Sustainable Systems and Technology (ISSST), pp – 1- 4.
- [14] Jian GAO, Longyun Yu, (2007), "Use of battery ohmic testing to improve network reliability and decrease battery maintenance cost", International Conference on Telecommunications Energy, pp – 194 – 202.
- [15] Jun Su, Fossa, C., Mak, T., (2011), "On heterogeneous mobile network connectivity: Number of gateway nodes", Military Communications Conference, pp – 1915 – 1920